

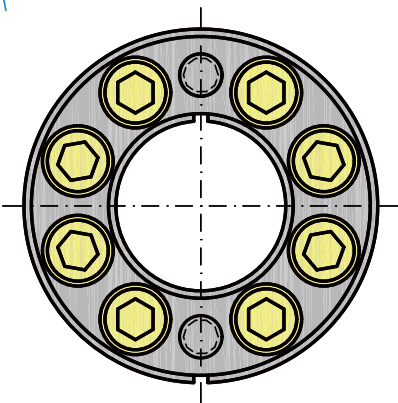

PH-A20

型號



PH-A 尺寸表

材質: S45C

單位: m/m

規格 NO	D	K	B	L	M	常規 扭力 (N.m)	軸向 荷重 (KN)	輪測 面壓 (N/mm ²)	重量 (kg)
PH-A20	20	47	20	26	M6	270	27	90	0.22
PH-A22	22	47	20	26	M6	300	27	90	0.23
PH-A24	24	50	20	26	M6	360	30	95	0.24
PH-A25	25	50	20	26	M6	380	30	95	0.24
PH-A28	28	55	20	26	M6	470	34	100	0.27
PH-A30	30	55	20	26	M6	500	34	100	0.28
PH-A32	32	60	20	26	M6	650	41	110	0.3
PH-A35	35	60	20	26	M6	700	41	110	0.32
PH-A38	38	65	20	26	M6	880	45	110	0.33
PH-A40	40	65	20	26	M6	950	47	110	0.35
PH-A42	42	75	24	32	M8	1600	75	130	0.55
PH-A45	45	75	24	32	M8	1700	75	130	0.58
PH-A48	48	80	24	32	M8	1800	75	120	0.59
PH-A50	50	80	24	32	M8	1900	75	120	0.62
PH-A55	55	85	24	32	M8	2300	85	130	0.64
PH-A60	60	90	24	32	M8	2500	85	120	0.68
PH-A65	65	95	24	32	M8	3000	95	130	0.73
PH-A70	70	110	28	38	M10	4800	130	130	1.3
PH-A75	75	115	28	38	M10	5000	130	130	1.35
PH-A80	80	120	28	38	M10	5300	130	130	1.42
PH-A85	85	125	28	38	M10	6400	150	140	1.5
PH-A90	90	130	28	38	M10	6500	160	140	1.56
PH-A95	95	135	28	38	M10	8000	170	140	1.63
PH-A100	100	145	30	42	M12	9700	190	140	2.23
PH-A110	110	155	30	42	M12	10600	200	130	2.37
PH-A120	120	165	30	42	M12	13000	210	130	2.6
PH-A130	130	180	38	50	M12	18000	270	120	3.6
PH-A140	140	190	38	50	M12	21000	300	120	3.75
PH-A150	150	200	38	50	M12	24000	320	120	4.1

